

Emergency Pack for Richie Rail 17, 20 & 26

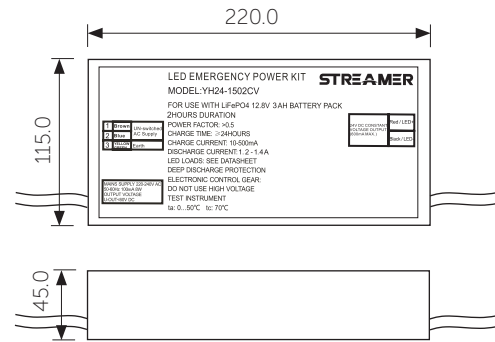
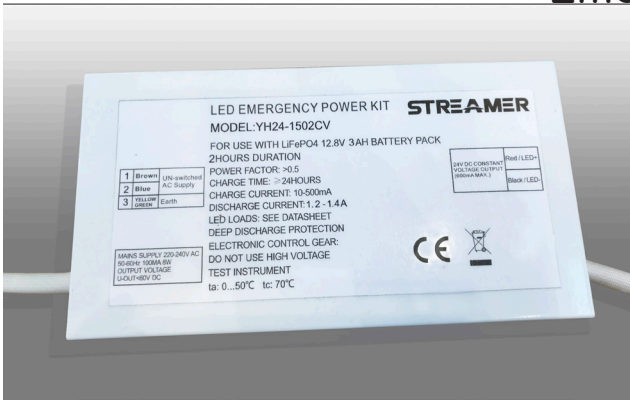

The YH24-1502CV Emergency Pack has been designed for use with our Richie Rail 17, Richie Rail 20 and Richie Rail 26 illuminated handrail series. Up to 5m of Spec Series Emergency LED strip will operate from the emergency pack for 2 hours during power failure providing light to critical escape routes.

FEATURES	GENERAL PRODUCT INFORMATION	COMPLIANT TO
Non-maintained	Product code: YH24-1502CV	Appendix C of AS/NZS 2293.3:2018, "Classification of Emergency Luminaires"***
2 hour discharge time*	Construction: Powder coated steel enclosure	CIE 121-1996
LiFePO4 battery pack	Mounting: Remote surface mount	AS/NZS 61347.1:2016
	Testing method: Manual test switch	IEC 61347-2-7:2011
	Protection: IP20	EN 55015
		IEC 60598-2-22

*YH24-1502CV will operate 5m of SPEC-15-40-2.5-40-EME Spec Series Emergency LED strip for 2 hours.

** Compliance to Appendix C of AS/NZS 2293.3:2018 is only achieved when used as a system with SPEC-15-40-2.5-40-EME Spec Series Emergency LED strip combined with Richie Rail 17, Richie Rail 20 and Richie Rail 26 illuminated handrail systems only.

ELECTRICAL PARAMETERS	
Charge	Discharge
Rated input voltage: 220-240VAC 50-60Hz	Battery pack: LiFePO4 12.8V 3000mAh 4S2P (IFR18650 1500mAh)
Rated input current: 100mA max.	Rated voltage: 12.8V
Rated input power: <math>< 8</math>W	Max. battery discharge current: 1.5A
Power factor: <math>< 0.50</math>	Output voltage: 24V DC constant voltage
Charge time: ≤ 16 hours	Output power: 15W max.
Charge current: 10---500mA	Deep discharge protection (V): 10 ± 0.2V
Charge voltage limit: 14.8V	Discharge efficiency: >math>> 80</math>%

BATTERY PACK	
Type:	LiFePO4 Battery 12.8V 3000MAh 4S2P (IFR18650 1500mAh)
Rated voltage:	12.8V
Capacity:	3000mAh
Max. charge voltage:	14.8V
Terminate discharge voltage:	10V
Ambient range:	Charge: 0...50°C, Discharge: 10...60°C
Charge discharge cycle:	>1000 full cycles
Storage temperature:	-10...35°C

WIRING

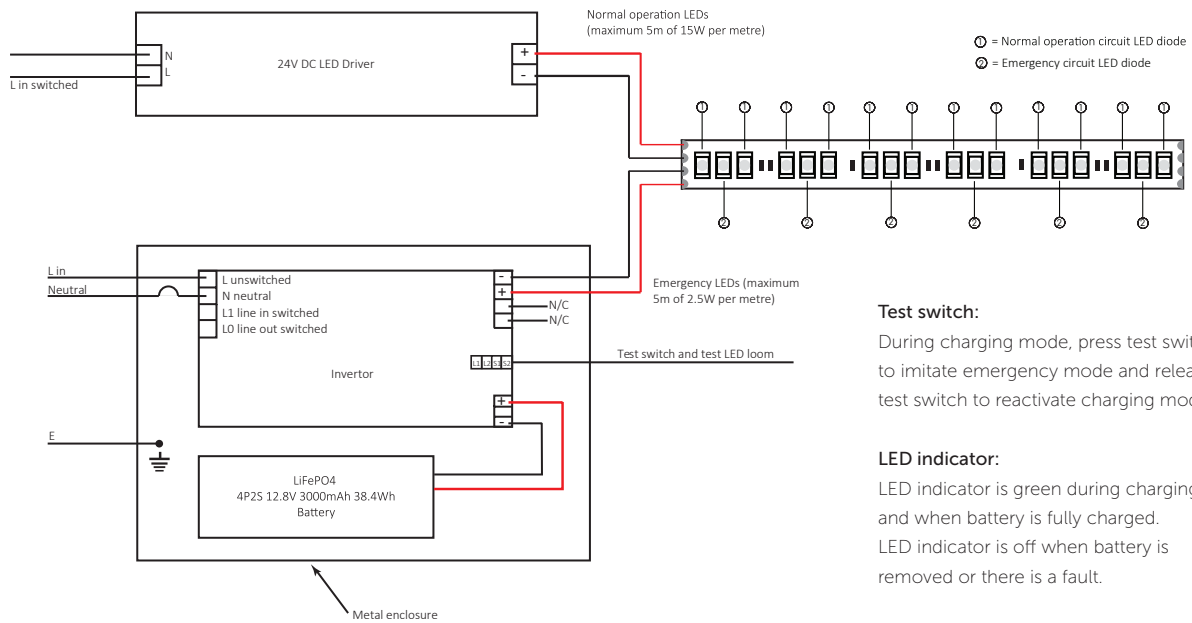

Test switch:

During charging mode, press test switch to imitate emergency mode and release test switch to reactivate charging mode.

LED indicator:

LED indicator is green during charging and when battery is fully charged.
 LED indicator is off when battery is removed or there is a fault.

Normal operation mode 15W p/m circuit is independent from the 2.5W p/m emergency mode circuit and can therefore be operated by any 24V DC remote LED driver (with adequate load) including non-dimmable, DALI or Casambi drivers.

INSTALLATION

1. Ensure mains are turned off.
2. Determine an appropriate, well ventilated and accessible position to locate remote emergency pack.
3. Remove lid from emergency pack and screw-fix into place, then replace lid.
4. Route mains AC power cables and SELV power cables to the enclosure and connect as per the wiring diagram above.
5. Turn power on and test.

Interconnecting cables: In accordance with AS/NZS2293, interconnecting cable between the emergency pack and the lamp source that is over 2m long should be fire-protected cable, class WS4X. If the cable traverses more than one fire compartment the interconnecting cable shall be provided with class WS4X protection.

Normal voltage drop calculations apply when determining the correct cable size.

TESTING

Testing should be conducted in accordance with AS/NZS2293.

1. Press and hold the test switch or turn off mains supply.
2. Check that the emergency LEDs turn on.
3. Release the test switch or turn mains supply back on.
4. Check that the emergency LEDs turn off (as this is a non-maintained system).

Important: This product must be installed and maintained by a licenced electrician and must be carried out in accordance with the relevant New Zealand and Australian Standards.