

1 PRODUCT OVERVIEW

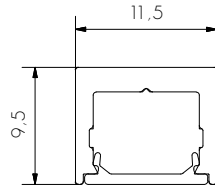

SLIM JIM 10

2 MOUNT EXTRUSION, MAKE ELECTRICAL CONNECTION, ASSEMBLE

1. DRILL 4.5MM MOUNTING HOLES AT APPROX. 400MM CENTRES.
2. DRILL CABLE ENTRY HOLE/S WHERE REQUIRED.
3. FEED LED STRIP TAILS THROUGH HOLE IN EXTRUSION. DO NOT INSTALL LED STRIP AT THIS POINT.
4. CONNECT LED STRIP TAILS TO LED DRIVER. DO NOT TURN POWER ON AT THIS POINT.
5. INSERT END CAPS IN TO EXTRUSION.
6. IF USING MULTIPLE LENGTHS OF EXTRUSION, ABUT EXTRUSIONS TOGETHER.
7. SCREW EXTRUSION TO SURFACE.

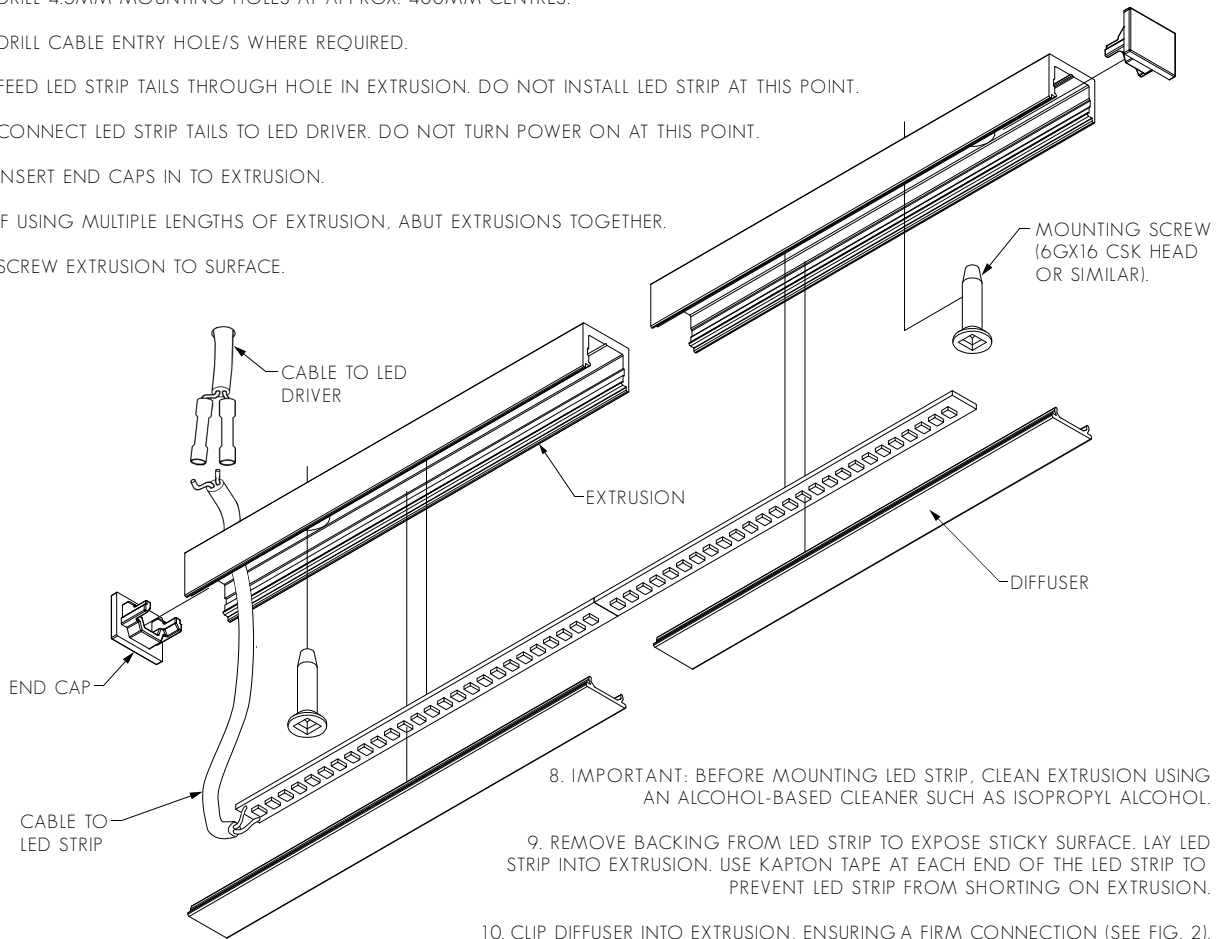

8. IMPORTANT: BEFORE MOUNTING LED STRIP, CLEAN EXTRUSION USING AN ALCOHOL-BASED CLEANER SUCH AS ISOPROPYL ALCOHOL.
9. REMOVE BACKING FROM LED STRIP TO EXPOSE STICKY SURFACE. LAY LED STRIP INTO EXTRUSION. USE KAPTON TAPE AT EACH END OF THE LED STRIP TO PREVENT LED STRIP FROM SHORTING ON EXTRUSION.
10. CLIP DIFFUSER INTO EXTRUSION, ENSURING A FIRM CONNECTION (SEE FIG. 2).

FIG. 1 - ENSURE EXTRUSION IS MOUNTED SECURELY

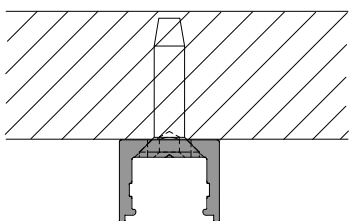

FIG. 2 - ENSURE DIFFUSER IS FITTED SECURELY

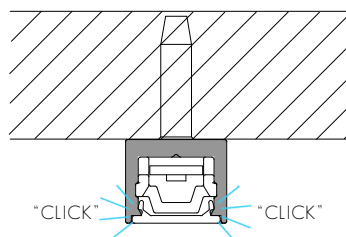
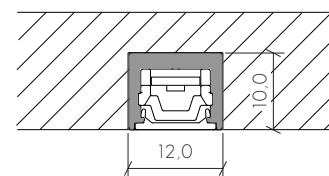

FIG. 3 - RECESSING



- DIMENSIONS SHOWN ARE FOR REBATE.  
- AFFIX PROFILE USING ADHESIVE, VHB TAPE OR BY SCREW-FIXING.