

1 PRODUCT OVERVIEW

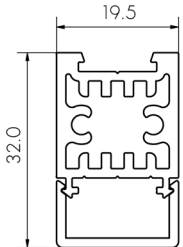

SIDEWAYS SALLY 20

2 FIX WALL BRACKETS IN TO A SOLID FIXING

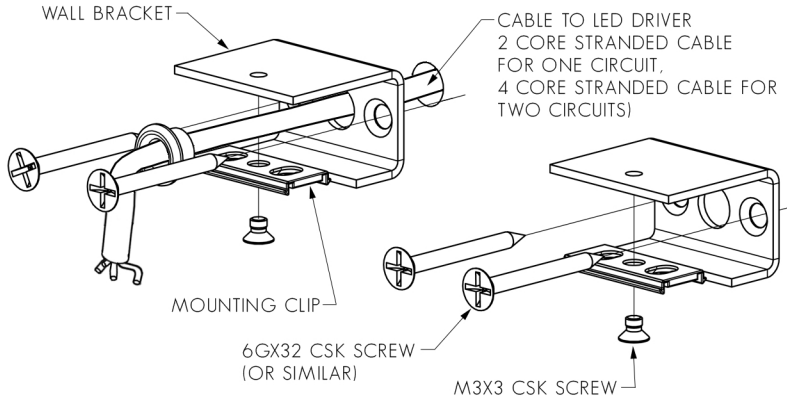

MAXIMUM DISTANCE BETWEEN WALL BRACKETS IS 800MM AND NO FURTHER THAN 200MM IN FROM AN END OR JOIN.

3 JOIN EXTRUSIONS, INSTALL LED STRIP, DIFFUSER AND END CAPS

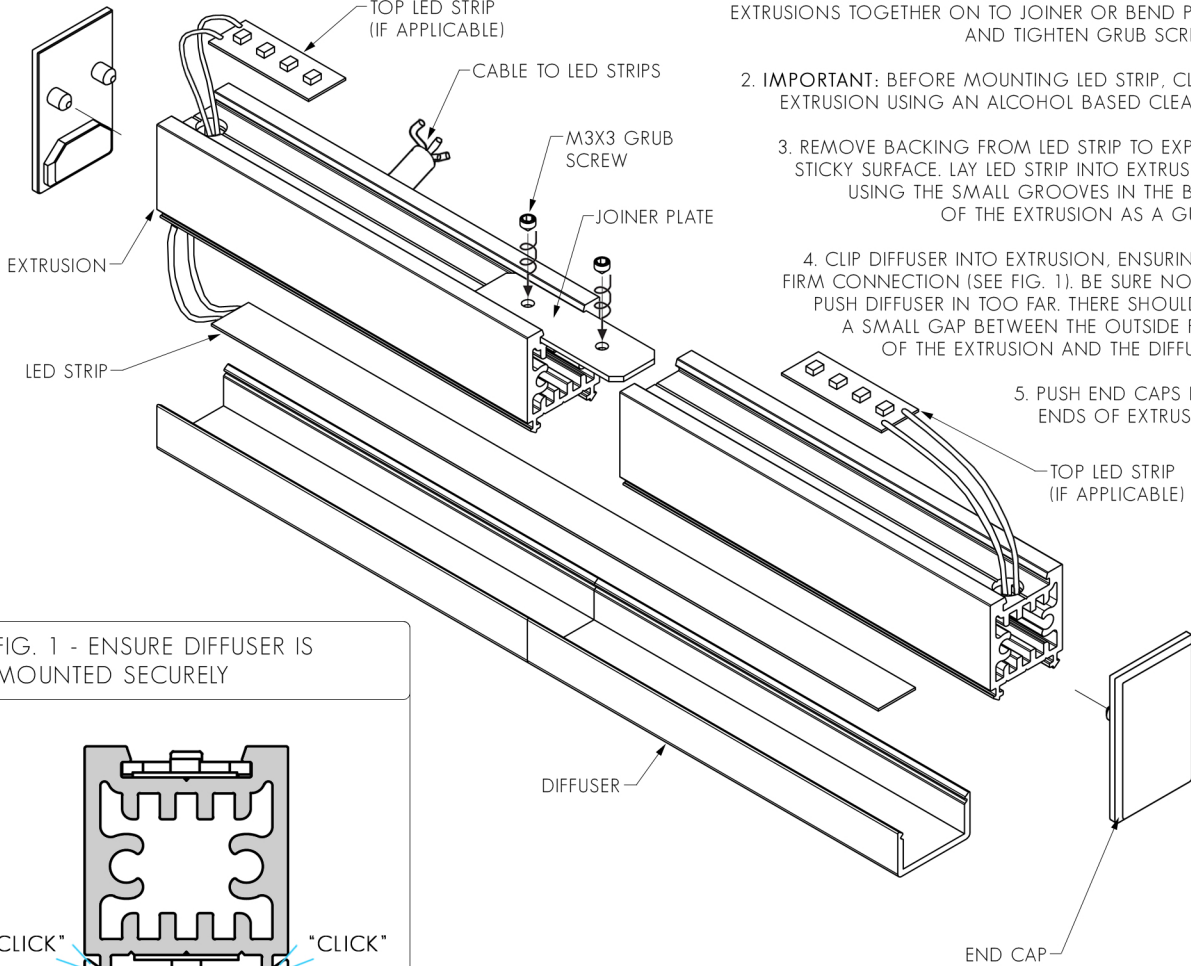

1. IF USING MULTIPLE LENGTHS OF EXTRUSION, SLIDE EXTRUSIONS TOGETHER ON TO JOINER OR BEND PLATE AND TIGHTEN GRUB SCREWS.
2. **IMPORTANT:** BEFORE MOUNTING LED STRIP, CLEAN EXTRUSION USING AN ALCOHOL BASED CLEANER.
3. REMOVE BACKING FROM LED STRIP TO EXPOSE STICKY SURFACE. LAY LED STRIP INTO EXTRUSION, USING THE SMALL GROOVES IN THE BACK OF THE EXTRUSION AS A GUIDE.
4. CLIP DIFFUSER INTO EXTRUSION, ENSURING A FIRM CONNECTION (SEE FIG. 1). BE SURE NOT TO PUSH DIFFUSER IN TOO FAR. THERE SHOULD BE A SMALL GAP BETWEEN THE OUTSIDE FACE OF THE EXTRUSION AND THE DIFFUSER.
5. PUSH END CAPS INTO ENDS OF EXTRUSION.

FIG. 1 - ENSURE DIFFUSER IS MOUNTED SECURELY

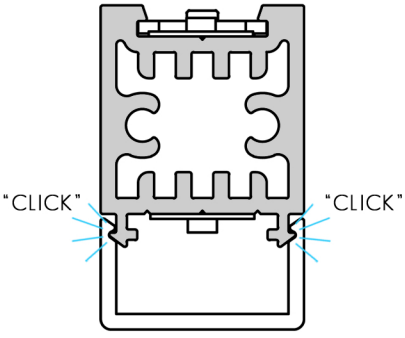

4

MAKE ELECTRICAL CONNECTION, FIX EXTRUSION TO WALL BRACKETS

1. MAKE ELECTRICAL CONNECTION: CONNECT LED STRIP TAILS TO LED DRIVER.

2. LIFT EXTRUSION ASSEMBLY AND CLIP EXTRUSION ON TO MOUNTING CLIPS ON WALL BRACKETS, ENSURING A FIRM CONNECTION (SEE FIG. 2).

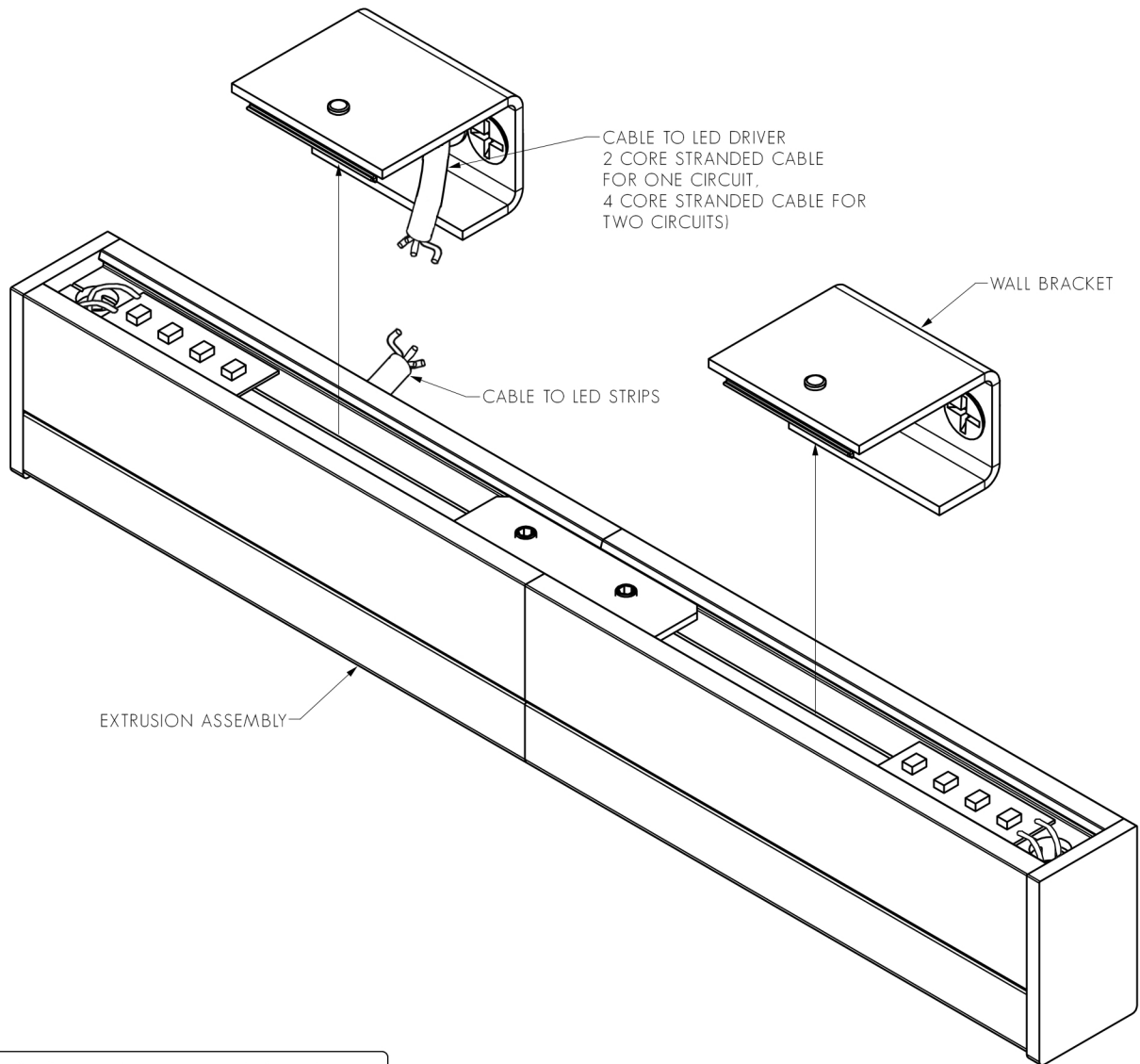

FIG. 2 - ENSURE EXTRUSION IS MOUNTED SECURELY

