

1 PRODUCT OVERVIEW

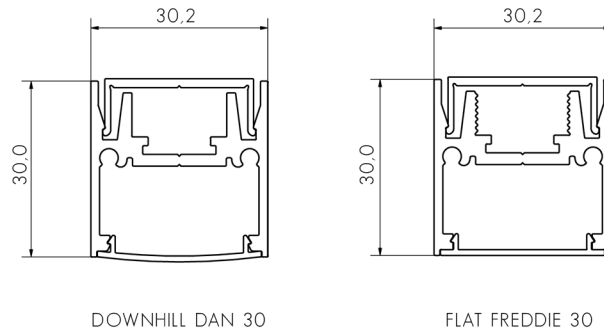

2 MOUNT EXTRUSION, MAKE ELECTRICAL CONNECTION.

1. DRAW A STRAIGHT LINE ON THE MOUNTING SURFACE TO ALIGN MOUNTING CLIPS.

NOTE: MAXIMUM SPACE BETWEEN MOUNTING CLIPS SHOULD BE 400MM. MOUNTING CLIPS MUST BE POSITIONED WITHIN 100MM OF EACH END AND WITHIN 100MM EITHER SIDE OF A JOIN OR BEND. E.G. A 1000MM EXTRUSION SHOULD HAVE 3 MOUNTING POINTS, ONE CENTRED AND ONE EACH END WITHIN 100MM.

2. SCREW MOUNTING CLIPS TO MOUNTING SURFACE USING PRE-DRILLED HOLES. **WARNING: DO NOT OVER-TIGHTEN. PLEASE NOTE THAT MOUNTING CLIPS MAY REQUIRE TWEAKING WITH PLIERS IF THEY DO NOT GRIP TIGHTLY.**

3. FEED LED STRIP TAILS (OR CABLE) THROUGH HOLE IN EXTRUSION AND CLAMP USING CORD GRIP SUPPLIED. (SEE FIG. 1 ON NEXT PAGE). DO NOT INSTALL LED STRIP AT THIS POINT.

4. MAKE ELECTRICAL CONNECTION: CONNECT LED STRIP TAILS TO LED DRIVER (SEE FIG. 2 ON NEXT PAGE IF SUPPLIED WITH MALE/FEMALE CONNECTORS).

5. CLIP EXTRUSION ON TO MOUNTING CLIPS, ENSURING A FIRM CONNECTION (SEE FIG. 3 ON NEXT PAGE).

6. IF USING MULTIPLE LENGTHS OF EXTRUSION, SLIDE EXTRUSIONS TOGETHER ON TO JOINER OR BEND PLATE.

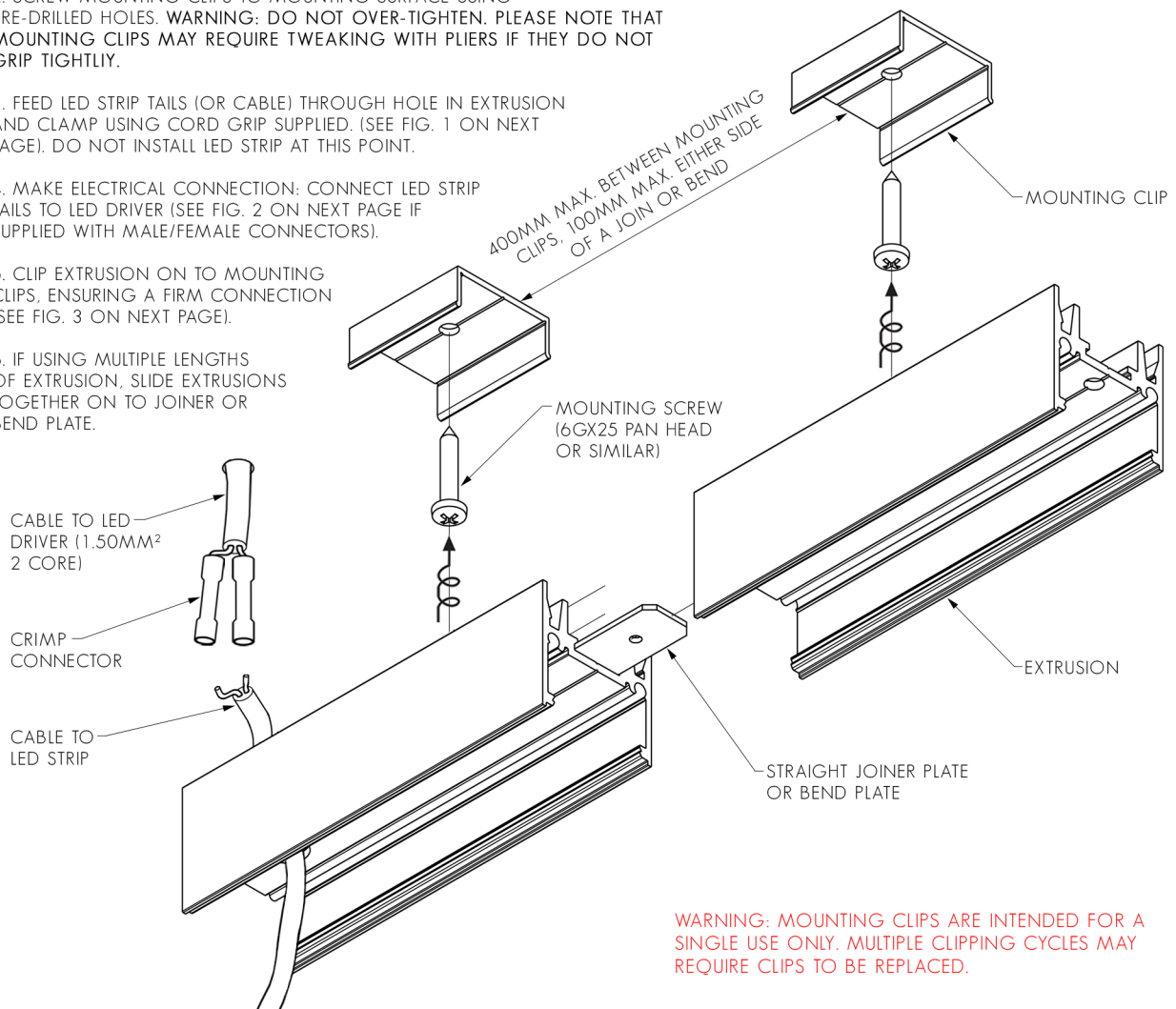

FIG. 1 - FASTEN CABLE USING CORD GRIP

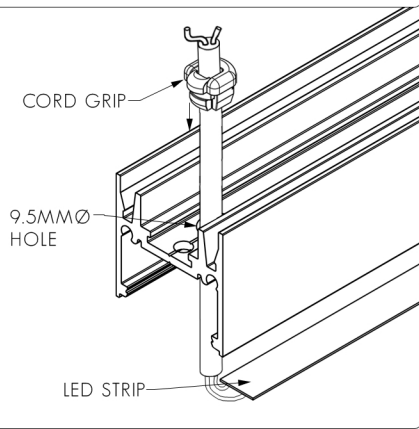

FIG. 2 - MAKE ELECTRICAL CONNECTION

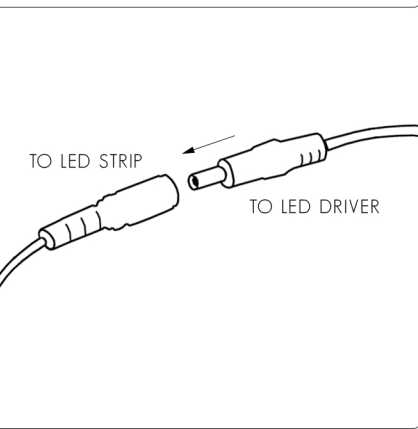
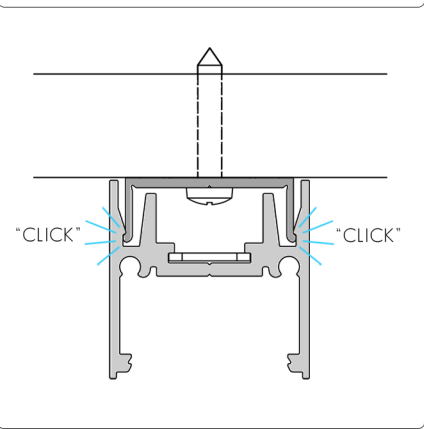

FIG. 3 - ENSURE EXTRUSION IS MOUNTED SECURELY



3 CLEAN EXTRUSION, INSTALL LED STRIP, DIFFUSER AND END CAPS

1. USE A SCREW AT EACH END OF THE EXTRUSION (BEYOND THE LED STRIP) TO SECURE EXTRUSION TO CEILING.
2. **IMPORTANT:** BEFORE MOUNTING LED STRIP, CLEAN EXTRUSION USING AN ALCOHOL BASED CLEANER.
3. REMOVE BACKING FROM LED STRIP TO EXPOSE STICKY SURFACE. LAY LED STRIP INTO EXTRUSION. USE A DAB OF SILICON AT EACH END OF THE LED STRIP TO PREVENT ENDS FROM LIFTING OFF EXTRUSION.
4. CLIP DIFFUSER INTO EXTRUSION, ENSURING A FIRM CONNECTION (SEE FIG. 4).
5. SLIDE END CAPS INTO ENDS OF EXTRUSION.

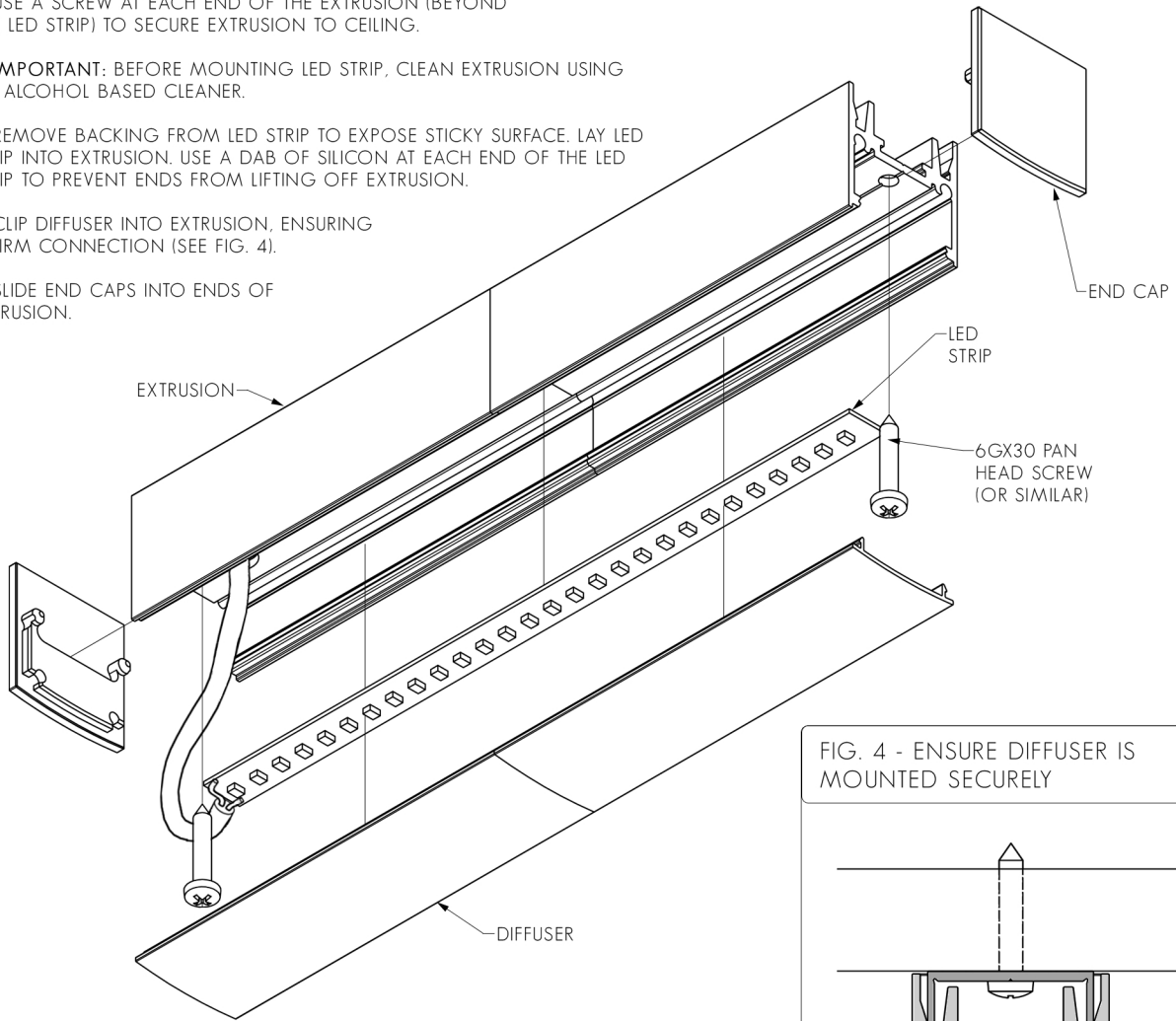

FIG. 4 - ENSURE DIFFUSER IS MOUNTED SECURELY

