

1

PRODUCT OVERVIEW

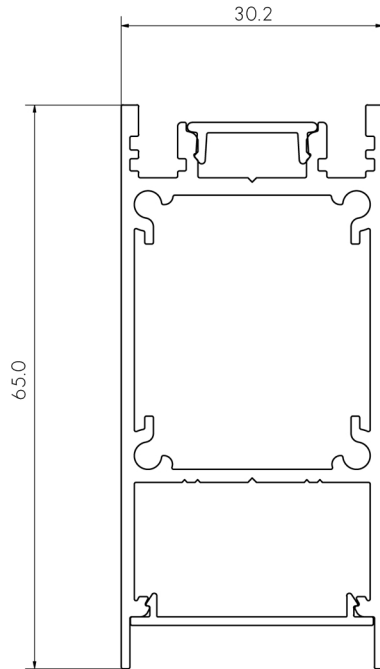

BOB EACH WAY 65

2

DRILL HOLES FOR SUSPENSION CEILING ATTACHMENTS AND INSTALL

NOTE: MOUNTING HOLES MUST BE DRILLED WITHIN 200MM OF EACH END OF THE EXTRUSION AND WITHIN 200MM EITHER SIDE OF A JOIN OR BEND. E.G. A 2500MM EXTRUSION SHOULD HAVE 3 MOUNTING POINTS, ONE CENTRED AND ONE EACH END WITHIN 200MM.

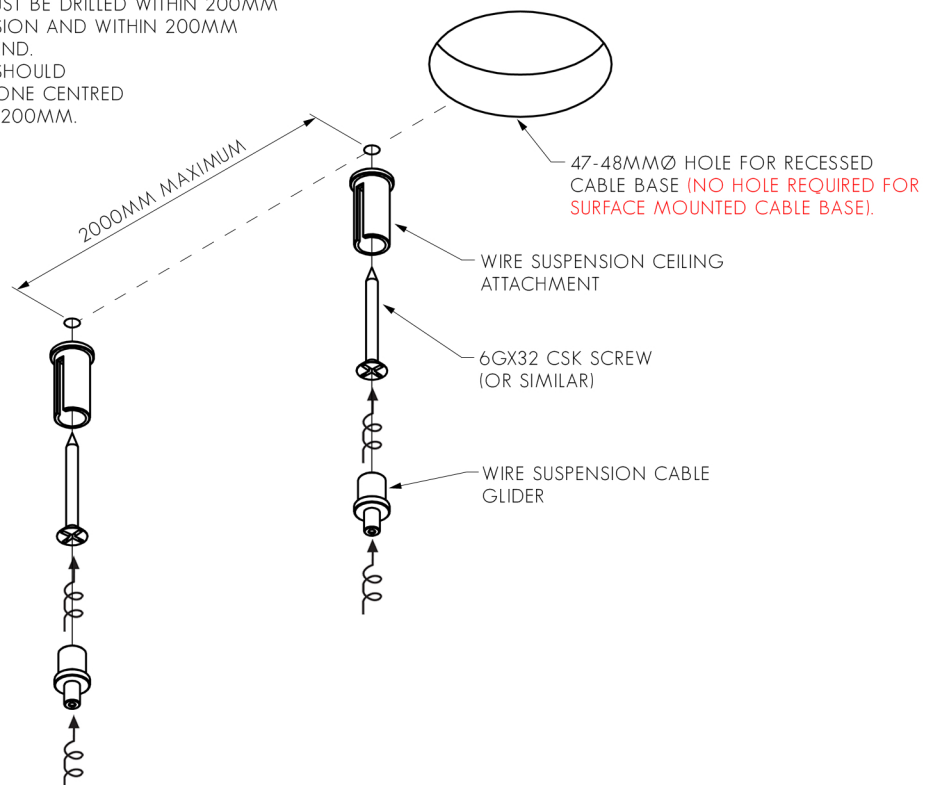

3 JOIN EXTRUSIONS, INSTALL LED STRIP & DIFFUSER

1. IF USING MULTIPLE LENGTHS OF EXTRUSION, SLIDE EXTRUSIONS TOGETHER ON TO JOINER OR BEND PLATE (SEE FIG. 1).
2. FEED LED STRIP CABLE THROUGH HOLE IN EXTRUSION AND CLAMP USING CORD GRIP SUPPLIED. (SEE FIG. 2).
3. **IMPORTANT:** BEFORE MOUNTING LED STRIP, CLEAN EXTRUSION USING AN ALCOHOL BASED CLEANER.
4. REMOVE BACKING FROM LED STRIP TO EXPOSE STICKY SURFACE. LAY LED STRIP INTO EXTRUSION, USING THE SMALL GROOVES IN THE BACK OF THE EXTRUSION AS A GUIDE.
5. CLIP DIFFUSERS INTO EXTRUSION, ENSURING A FIRM CONNECTION (SEE FIG. 1).

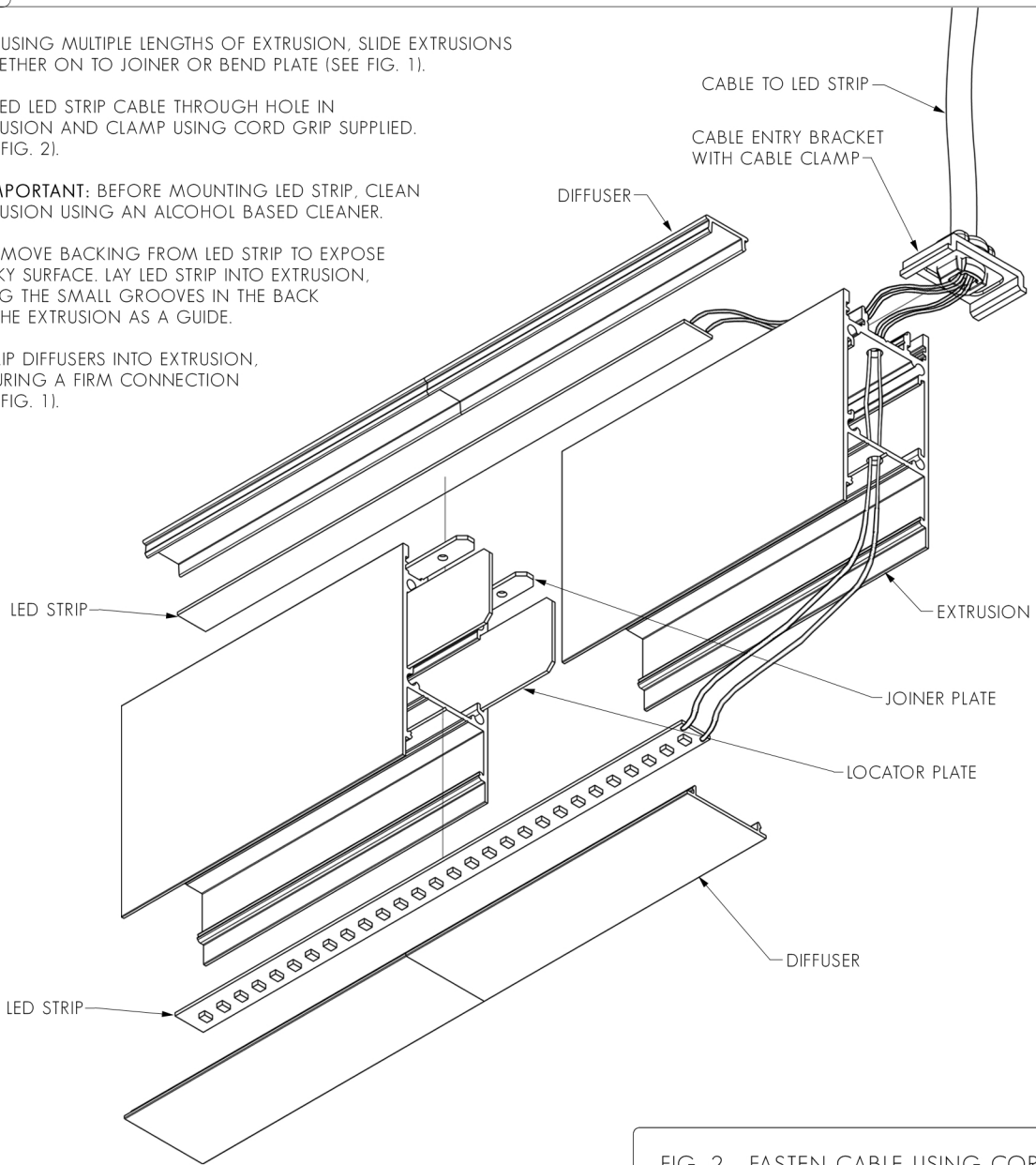

FIG. 1 - ENSURE DIFFUSER IS MOUNTED SECURELY

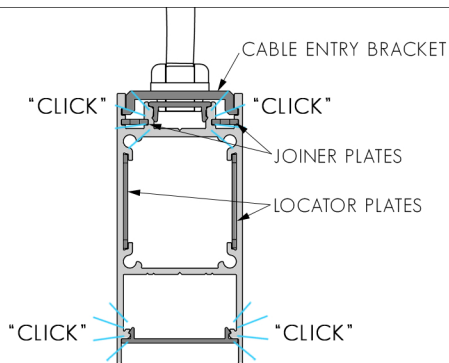
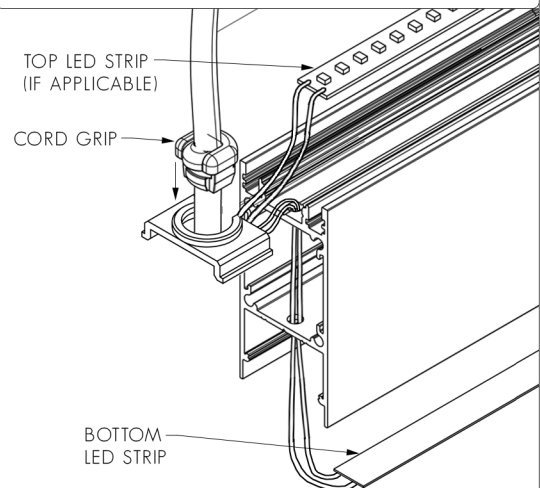

FIG. 2 - FASTEN CABLE USING CORD GRIP



4 INSTALL SUSPENSIONS, END CAPS, MAKE ELECTRICAL CONNECTION, INSTALL CABLE BASE,

1. FEED WIRE SUSPENSION CABLES THROUGH SUSPENSION BRACKETS, THEN SLIDE SUSPENSION BRACKETS IN TO TOP GROOVES EXTRUSION.
2. FEED WIRE SUSPENSION CABLES IN TO CEILING ATTACHMENTS. PRESS NIPPLE INWARDS TO ADJUST CABLE LENGTH (SEE FIG. 3).
3. ONCE CORRECT SUSPENSION HEIGHT HAS BEEN SET, CUT OFF EXCESS SUSPENSION WIRE USING SIDE CUTTERS. (SEE FIG. 3).
4. PUSH END CAPS INTO ENDS OF EXTRUSION.
5. MAKE ELECTRICAL CONNECTION: CONNECT LED STRIP TAILS TO LED DRIVER.
6. PUSH CABLE BASE INTO HOLE IN CEILING (SEE FIG. 4), OR FIG. 5 FOR SURFACE MOUNTED CABLE BASE.

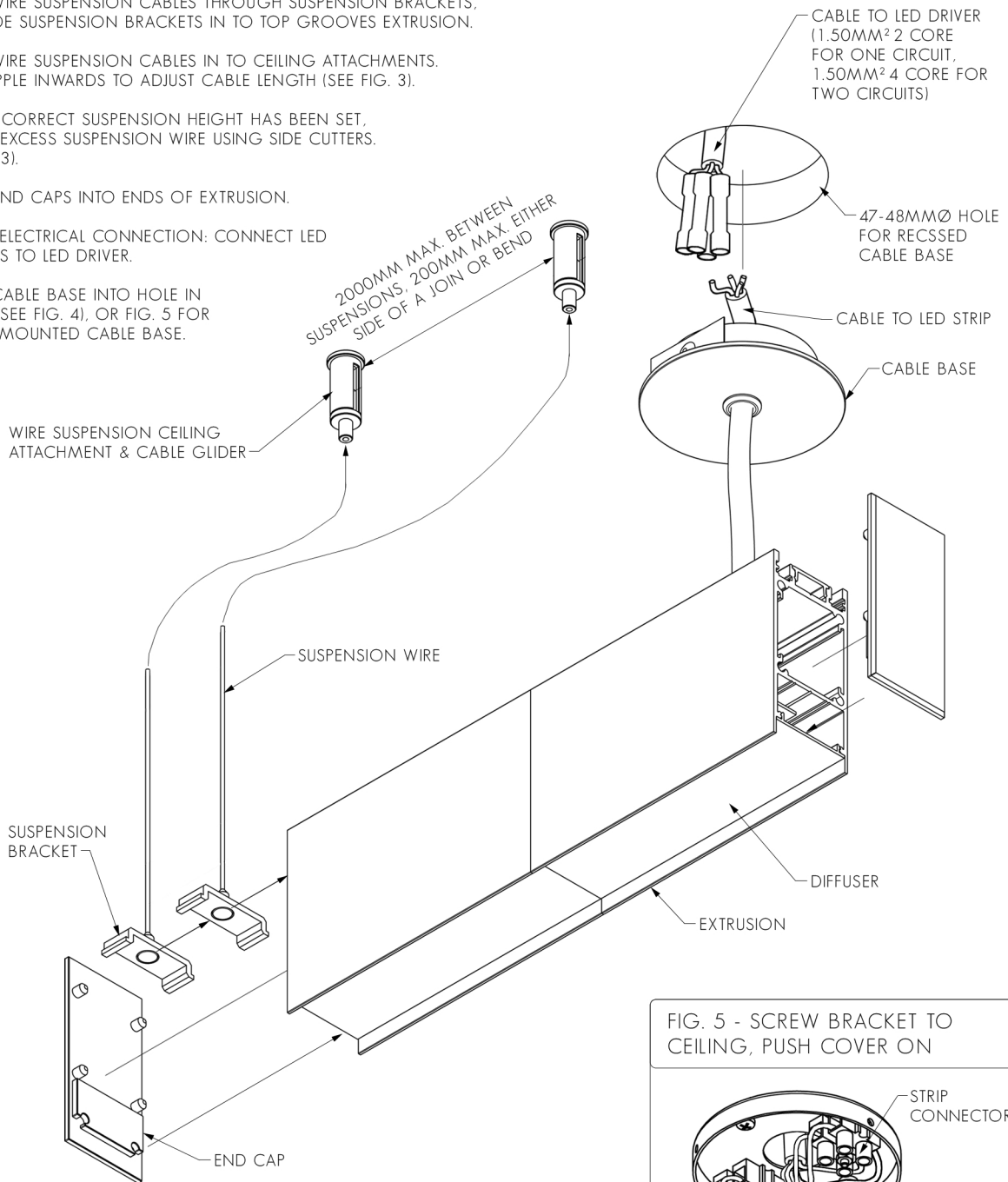

FIG. 3 - ADJUST SUSPENSION CABLE

ONCE SUSPENSION LENGTH HAS BEEN SET, CUT OFF EXCESS SUSPENSION CABLE

PRESS TO ADJUST CABLE LENGTH

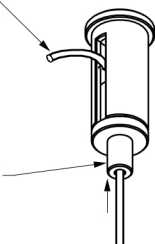

FIG. 4 - INSERT CABLE BASE IN TO CEILING

ANGLE CABLE UP IN TO HOLE, USING THUMBS TO COMPRESS SPRING CLIP ON ONE SIDE.

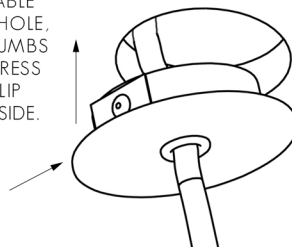

FIG. 5 - SCREW BRACKET TO CEILING, PUSH COVER ON

